

Crux

Published by the Canadian Mathematical Society.



<http://crux.math.ca/>

The Back Files

The CMS is pleased to offer free access to its back file of all issues of *Crux* as a service for the greater mathematical community in Canada and beyond.

Journal title history:

- The first 32 issues, from Vol. 1, No. 1 (March 1975) to Vol. 4, No.2 (February 1978) were published under the name *EUREKA*.
- Issues from Vol. 4, No. 3 (March 1978) to Vol. 22, No. 8 (December 1996) were published under the name *Crux Mathematicorum*.
- Issues from Vol 23., No. 1 (February 1997) to Vol. 37, No. 8 (December 2011) were published under the name *Crux Mathematicorum with Mathematical Mayhem*.
- Issues since Vol. 38, No. 1 (January 2012) are published under the name *Crux Mathematicorum*.

Mathematicorum

ISSN 0705 - 0348

CRUX MATHEMATICORUM

Vol. 6, No. 1

January 1980

Sponsored by
Carleton-Ottawa Mathematics Association Mathématique d'Ottawa-Carleton
Publié par le Collège Algonquin

The assistance of the publisher and the support of the Canadian Mathematical Olympiad Committee, the Carleton University Mathematics Department, the Ottawa Valley Education Liaison Council, and the University of Ottawa Mathematics Department are gratefully acknowledged.

CRUX MATHEMATICORUM is a problem-solving journal at the senior secondary and university undergraduate levels for those who practise or teach mathematics. Its purpose is primarily educational, but it serves also those who read it for professional, cultural, or recreational reasons.

It is published monthly (except July and August). The yearly subscription rate for ten issues is \$10.00. Back issues: \$1.00 each. Bound volumes with index: Vols. 1&2 (combined), \$10.00; Vols. 3,4,5, \$10.00 each. Cheques and money orders, payable to CRUX MATHEMATICORUM (in US funds from outside Canada), should be sent to the managing editor.

All communications about the content of the magazine (articles, problems, solutions, etc.) should be sent to the editor. All changes of address and inquiries about subscriptions and back issues should be sent to the managing editor.

Editor: Léo Sauv , Architecture Department, Algonquin College, 281 Echo Drive, Ottawa, Ontario, K1S 1N3.

Managing Editor: F.G.B. Maskell, Mathematics Department, Algonquin College, 200 Lees Ave., Ottawa, Ontario, K1S 0C5.

Typist-compositor: Gorette C.F. Luk.

* * *

CONTENTS

To Err is Human	O. Bottema	2
Mama-Thematics	Charles W. Trigg	4
Solving Cubic Equations on a Pocket Calculator	John Rausen	5
Two Timely Problems	Howard Eves	7
Postscript	Leroy F. Meyers	8
Mathematical Swifties	M.S.K.	9
Solutions to "Two Timely Problems"	Howard Eves	10
The Olympiad Corner: 11	Murray S. Klamkin	10
Problems - Probl�mes		14
Solutions		17
Sic Transit...		32

TO ERR IS HUMAN¹

O. BOTTEMA

In several advanced books on solid geometry (see, e.g., [1]-[5]), and even in some elementary textbooks, we find the following nice theorem:

THEOREM 1. Any plane passing through a bimedian of a tetrahedron bisects the volume of the tetrahedron.

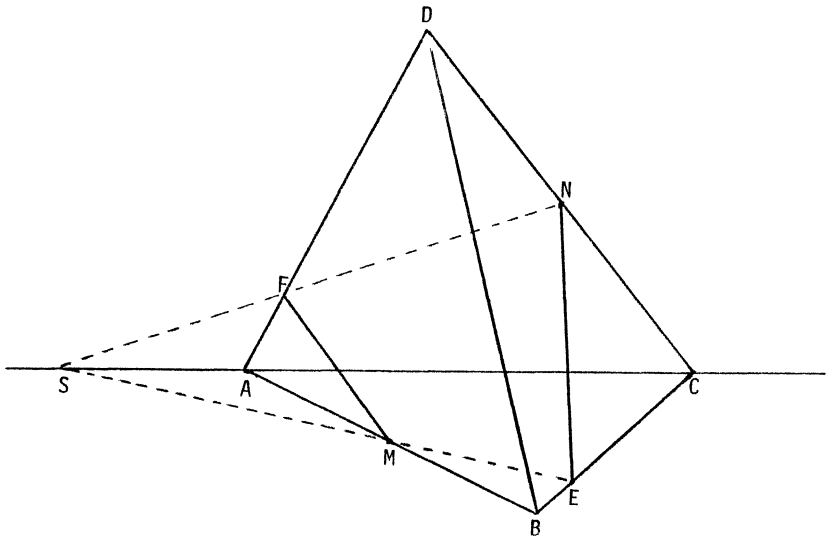

The proof usually goes as follows. Let $T = ABCD$ be the tetrahedron, M and N the midpoints of AB and CD , and let an arbitrary plane through the bimedian MN meet the edges BC and AD in E and F , as shown in the figure. It follows that ME and NF intersect at a point S on AC . If we apply the theorem of Menelaus to triangle ABC with line of intersection MS , and to triangle ADC with NS , we obtain $BE/EC = AF/FD$, and therefore $BE/BC = AF/AD$.

Of the two parts of the tetrahedron, one is the sum of the pyramid $P_1 = D-MENF$ and the tetrahedron $T_1 = D-BEM$; the other is the sum of the pyramid $P_2 = C-MENF$ and the tetrahedron $T_2 = C-AMF$. Now P_1 and P_2 have the same base and equal altitudes; hence their volumes are equal. The tetrahedra $T_1 = B-MED$ and $T = B-ACD$ have tri-

¹Reprinted, by permission of the author and editors, from *Euclides*, 49 (1973-74) 228-229. Translated from the Dutch by Miss Femke LaGro.

hedral angle B in common, while $T_2 = A\text{-MFC}$ and $T = A\text{-BDC}$ have trihedral angle A in common; and it is known that the volumes of two tetrahedra with a common trihedral angle are proportional to the products of the respective edges. From this we get the volume ratios

$$T_1 : T = BE : 2BC \quad \text{and} \quad T_2 : T = AF : 2AD,$$

which implies

$$T_1 : T_2 = (BE/BC) : (AF/AD) = 1.$$

Thus $T_1 = T_2$ and the proof is complete.

This theorem is due to Bobillier, who published it in 1827 [6]². We draw attention to it now because of a remarkable sequel, an apparently justified generalization whose proof, however, is founded on a curious mistake. It was published a year later by Lévy [7] and reads as follows:

"THEOREM" 2. Let ABCD be a tetrahedron. If M and N divide the edges AB and DC in the same ratio, say,

$$AM : MB = DN : NC = p : q,$$

then any plane through MN divides the tetrahedron into two parts whose volumes are in the ratio $p : q$.

Bobillier's theorem deals with the special case $p = q$.

It is easy to see that this "theorem" cannot be true. For suppose some plane through MN cuts the tetrahedron into two parts which we will call the front part and the back part. Now imagine the plane to be rotated about MN. As it rotates, both the front and back parts have constant volumes if the "theorem" is true; yet after a half-turn they are interchanged. Hence the "theorem" can only be true if $p = q$.

It is not difficult to find out what may have gone wrong in Lévy's argument. If we use the same reasoning as before, we find that

$$P_1 : P_2 = AM : MB = DN : NC = p : q,$$

and the application of the theorem of Menelaus yields again $BE/BC = AF/AD$. However, we now have

$$T_1 : T_2 = (BE/BC)(BM/BA) : (AF/AD)(AM/AB) = BM : AM = q : p.$$

The terms of the ratio are correct but they are *in the wrong order*, and therefore the conclusion fails.

²Altshiller-Court [5, p. 341] does not give the Bobillier reference [6], but he gives an earlier one and does not identify the author: *Annales de mathématiques*, 1 (1810-1811) 230, 253. (Editor of C.M.)

It is very likely that some readers spotted the mistake in Lévy's argument shortly after its publication in 1828 and notified the author or the editors of the *Correspondance*. It is nonetheless a fact that, right up to the present day, "Theorem" 2 has been given and "proved" to be true in some very serious and outstanding works which have gone through many editions; for example, F.G.-M. [4] and Altshiller-Court [5]³.

A few years ago [8], we investigated, for arbitrary positions of M and N on the edges AB and DC, the ratio of the volumes of the two parts of the tetrahedron as the plane of intersection rotates about MN. It appears to be a quadratic function of the position of the plane, continuous but with a discontinuous derivative for the special positions NAB and MCD. Except for the case when M and N are both midpoints, there is one and only one plane through MN such that the two parts have the same volume.

REFERENCES

1. G. Holzmüller, *Elemente der Stereometrie*, Leipzig, 1900, Bnd. 2, p. 344.
2. J. Hadamard, *Leçons de géométrie élémentaire*, Paris⁴, 1932, T. 2, p. 112.
3. Molenbroek, *Leerboek der stereometrie*, Groningen, 1949, pp. 174-175.
4. F.G.-M., *Exercices de géométrie*, quatrième édition, Mame et Fils, Tours, 1907, pp. 871-872.
5. Nathan Altshiller-Court, *Modern Pure Solid Geometry*, Macmillan, New York, 1935, pp. 89. Second edition, Chelsea, New York, 1964, pp. 98-99.
6. Bobillier, "Tout plan qui passe par la droite que déterminent les milieux des arêtes opposées d'un tétraèdre, le divise en deux parties équivalentes," *Correspondance mathématique et physique*, 3 (1827) 181-182.
7. A. Lévy, *Correspondance mathématique et physique*, 4 (1828) 3.
8. O. Bottema, "A theorem of Bobillier on the tetrahedron," *Elemente der Mathematik*, 24 (1969) 6-10.

Charlotte de Bourbonstraat 2, 2628 BN Delft, The Netherlands.

*

*

*

MAMA-THEMATICS

Mrs. Conway, about son John: "Ever since he was boy he's been a game kid."

CHARLES W. TRIGG

³In fact, Altshiller-Court first "proves" "Theorem" 2 and then deduces Theorem 1 as a corollary! (Editor of *C.M.*)

⁴Altshiller-Court [5, p. 337] gives 1901 rather than 1932 as the date of publication. Different editions may account for the discrepancy. (Editor of *C.M.*)

SOLVING CUBIC EQUATIONS ON A POCKET CALCULATOR

JOHN RAUSEN

In the classical theory (see any of the references given below or any book on the theory of equations), the cubic equation

$$z^3 + Bz^2 + Cz + D = 0$$

is reduced to the form

$$y^3 + py + q = 0 \tag{1}$$

by the substitution $z = y - B/3$. Assume the coefficients are real. Then the nature of the roots y_0, y_1, y_2 of (1) depends on the sign of the discriminant

$$(y_0 - y_1)^2 (y_0 - y_2)^2 (y_1 - y_2)^2 = -\Delta,$$

where $\Delta = 4p^3 + 27q^2$.

Cardan's formulas, which provide an *algebraic* solution, are not practical for numerical computation, especially when $\Delta < 0$, for then the three roots (which are all real) are given as sums of two imaginary cube roots. In this so-called "irreducible case," the equation *cannot* be solved by real radicals only ([3], p. 180); but there is a well-known method of expressing the roots in terms of *transcendental* (trigonometric and inverse trigonometric) functions, based on the identity

$$\cos 3\theta = 4 \cos^3 \theta - 3 \cos \theta, \tag{2}$$

the details of which will be recalled below. No longer a mere historical curiosity, this procedure should be an interesting and useful topic for a precalculus college course in algebra and trigonometry, now that students may own inexpensive "scientific" calculators, which include trigonometric functions and their inverses.

Apparently not so well-known is the fact (see [1], [4]) that hyperbolic functions provide a convenient numerical solution when $\Delta > 0$, which gives both the real and imaginary roots by means of the identities

$$\cosh 3t = 4 \cosh^3 t - 3 \cosh t, \tag{3}$$

$$\sinh 3t = 4 \sinh^3 t + 3 \sinh t, \tag{4}$$

and the periodicity of the hyperbolic functions (period $2\pi i$). Again, the formulas are highly suitable for computations on a pocket calculator having at least " e^{2x} " and " $\ln x$ " buttons, and preferably the hyperbolic and inverse hyperbolic functions,

although one can always use the formulas

$$\begin{aligned} \cosh t &= \frac{1}{2}(e^t + e^{-t}), & \cosh^{-1} t &= \ln(t + \sqrt{t^2 - 1}), \\ \sinh t &= \frac{1}{2}(e^t - e^{-t}), & \sinh^{-1} t &= \ln(t + \sqrt{t^2 + 1}). \end{aligned}$$

We now describe briefly the procedure for solving the reduced equation (1). We assume $p \neq 0$ since otherwise the problem is trivial. The substitution $y = kx$, where $k = 2\sqrt{|p|/3}$, transforms (1) to

$$4x^3 \pm 3x = b, \tag{5}$$

where $b = -4q/k^3$.

Case 1. $4x^3 - 3x = b$. There are three subcases to consider:

(i) $-1 \leq b \leq 1$. If we let $\beta = (1/3)\cos^{-1} b$, then it follows from (2) that $x_n = \cos(\beta + 2n\pi/3)$ is a solution for every integer n , and we can take

$$x_0 = \cos \beta, \quad x_1 = \cos(\beta + 2\pi/3), \quad x_2 = \cos(\beta + 4\pi/3)$$

as the three required roots. (This includes the case of a double root, which will appear twice, if $b = \pm 1$.)

(ii) $b > 1$. Here we let $\beta = (1/3)\cosh^{-1} b$, and it follows from (3) that $x_n = \cosh(\beta + 2n\pi i/3)$ is a solution for every integer n . We take $n = 0, 1, 2$ again and expand to find the three distinct roots

$$x_0 = \cosh \beta, \quad x_1, x_2 = -\frac{1}{2} \cosh \beta \pm i(\sqrt{3}/2) \sinh \beta.$$

(iii) $b < -1$. This time we let $\beta = (1/3)\cosh^{-1}(-b)$, and it follows from (3) that $x_n = -\cosh(\beta + 2n\pi i/3)$ is a solution for every integer n . The three distinct roots are

$$x_0 = -\cosh \beta, \quad x_1, x_2 = \frac{1}{2} \cosh \beta \mp i(\sqrt{3}/2) \sinh \beta.$$

Case 2. $4x^3 + 3x = b$. We let $\beta = (1/3)\sinh^{-1} b$, and it follows from (4) that $x_n = \sinh(\beta + 2n\pi i/3)$ is a solution for every integer n . The three distinct roots are

$$x_0 = \sinh \beta, \quad x_1, x_2 = -\frac{1}{2} \sinh \beta \pm i(\sqrt{3}/2) \cosh \beta.$$

In all cases, the roots of (1) are $y_n = kx_n$, where k is the constant used to transform (1) into (5).

Examples. We will solve the equations $y^3 \pm 4y + 6 = 0$. We have $\Delta > 0$ for both equations, so each has one real and two imaginary roots. Also, for each equation we have

$$k = 4/\sqrt{3} \approx 2.309401077 \quad \text{and} \quad b = -9\sqrt{3}/8 \approx -1.948557159.$$

The equation $y^3 - 4y + 6 = 0$ transforms into $4x^3 - 3x = b$, so we apply the procedure of Case 1 (iii). With

$$\beta = (1/3) \cosh^{-1}(-b) \approx 0.4289115129,$$

we find

$$x_0 \approx -1.09340135, \quad x_1, x_2 \approx 0.546700675 \mp 0.382942403i$$

and

$$y_0 \approx -2.525102, \quad y_1, y_2 \approx 1.262551 \mp 0.8843676i.$$

The equation $y^3 + 4y + 6 = 0$ transforms into $4x^3 + 3x = b$, so now we use the procedure of Case 2. With

$$\beta = (1/3) \sinh^{-1} b \approx -0.4734633221,$$

we find

$$x_0 \approx -0.4913518336, \quad x_1, x_2 \approx 0.2456759168 \pm 0.9649196693i$$

and

$$y_0 \approx -1.134728, \quad y_1, y_2 \approx 0.5673642 \pm 2.228387i.$$

To preserve accuracy, all calculations were carried out to the full capacity of the calculator, except the final values y_n which were rounded off.

REFERENCES

1. Paul Appell, *Analyse mathématique*, 5^e édition, Gauthier-Villars, Paris, 1937.
2. D.E. Littlewood, *A University Algebra*, 2nd edition, Heinemann, London, 1958.
3. B.L. van der Waerden, *Modern Algebra*, Vol. I, F. Ungar, New York, 1949.
4. E. U. Condon and H. Odishaw (editors), *Handbook of Physics*, McGraw-Hill, New York, 1958 (Chapter I.2: Algebra, by Olga Tausky).

Department of Mathematics, New Jersey Institute of Technology, 323 High Street, Newark, N.J. 07102.

*

*

*

TWO TIMELY PROBLEMS

(In memory of LEO MOSER)

Problem 1.

Write down any number from the square array of numbers given below, and cross out the row and column in which that number is located. Now write down another number from the array, not yet crossed out, and again cross out the row and column in which that number is located. Continue in this way until all numbers in the

array have been crossed out. The problem is to carry out the above process in such a way that the sum of the numbers written down is 1980.

213	356	161	246	363	159
459	602	407	492	609	405
245	388	193	278	395	191
303	446	251	336	453	249
382	525	330	415	532	328
158	301	106	191	308	104

Problem 2.

Place the digits 0, 1, 2, 3, 4, 5, 6, 7, 8, 9 in the ten blank spaces, in such an order that the indicated division will have a remainder of 1980.

$$3168 \overline{) 71 _ 543 _ 2 _ 985 _ 2 _ 356 _ 8 _ 7 _ 836 _ 7 _ 39996}.$$

HOWARD EVES,
University of Maine.

Solutions to these problems appear on page 10 in this issue.

*

*

*

POSTSCRIPT

Clayton W. Dodge's recent article, "A General Divisibility Test" [1979: 246], contains several useful tests for divisibility, some of which are related to Charles L. Dodgson's methods [1,2]. However, my favorite tests for divisibility by 7 and by 17 were omitted, although some related tests are presented.

My favorite tests replace the base ten by a higher power of ten. Since $10^2 = 7 \cdot 14 + 2$ and $10^2 = 17 \cdot 6 - 2$, the divisibility sets (1,2,4) for 7 and (1,-2,4,-8, -1,2,-4,8) for 17 may be used with *pairs* of decimal digits, beginning at the position of the decimal point. Thus, in testing 6312785 for divisibility by 7 and by 17, we have, in Dodge's notation,

$$\begin{array}{r} 1 \quad 4 \quad 2 \quad 1 \\ 06 \quad 31 \quad 27 \quad 85 \\ \hline 6 + 124 + 54 + 85 = 269 \end{array} \quad \text{and} \quad \begin{array}{r} 2 \quad 1 \\ 02 \quad 69 \\ \hline 4 + 69 = 73 \end{array}$$

$$\begin{array}{r} -8 \quad 4 \quad -2 \quad 1 \\ 06 \quad 31 \quad 27 \quad 85 \\ \hline -48 + 124 - 54 + 85 = 107 \end{array} \quad \text{and} \quad \begin{array}{r} -2 \quad 1 \\ 01 \quad 07 \\ \hline -2 + 7 = 5 \end{array}$$

(Note that an initial 0 may be needed in order to fill out a pair.) Thus

$$6312785 \equiv 73 \equiv 3 \pmod{7} \quad \text{and} \quad 6312785 \equiv 5 \pmod{17}.$$

Since $10^3 - 1 = 3^3 \cdot 37$ and $10^4 + 1 = 73 \cdot 137$, we may use the divisibility set (1) with triples of digits to test for divisibility by 3^3 and 37, and the set (1,-1) with quadruples of digits to test for divisibility by 73 and 137.

It is often desirable to test for divisibility by higher powers of primes. The usual single-digit set (1) tests for divisibility by 3^2 as well as by 3 and, as we have just seen, the triple-digit set (1) tests for divisibility by 3^3 . But the double-digit set (1,2,4,8,16,32,64,...) tests for divisibility by 7^2 as well as by 7, and may be written (but less easily remembered) in the reduced form (1,2,4,8,16,-17,15,-19,11,22,-5,-10,-20,9,18,-13,23,-3,-6,-12,-24).

Sometimes it is more convenient to use digit weights that can be written in the same order as the digits of the number being tested. For example, the sets (1,2,4,8,16,...) and (1,4,3,-1,-4,-3) test for divisibility by 19 and 13, respectively, as seen from the following examples:

$$\begin{array}{rcccccccc} 1 & 2 & 4 & 8 & -3 & -6 & 7 & \\ \hline 6 & 3 & 1 & 2 & 7 & 8 & 8 & \\ \hline 6 + & 6 + & 4 + & 16 - & 21 - & 48 + & 56 = & 19^9 \end{array} \qquad \begin{array}{rcccccccc} 1 & 4 & 3 & -1 & -4 & -3 & 1 & \\ \hline 6 & 3 & 1 & 2 & 7 & 8 & 7 & \\ \hline 6 + & 12 + & 3 - & 2 - & 28 - & 24 + & 7 = & -26^8 \end{array}$$

Thus 6312788 and 6312787 are divisible by 19 and 13, respectively. However, in case of nondivisibility, the remainder is not so easily determined.

REFERENCES

1. Charles L. Dodgson, "Brief method of dividing a given number by 9 and 11", *Nature*, 56 (14 October 1897) 565-566. (Also several other articles in neighboring volumes of *Nature*.)
2. _____, (Fragment of) *Curiosa Mathematica*, part III, chapters II and III, printed in Stuart Dodgson Collingwood, *Diversions and Digressions of Lewis Carroll* (formerly entitled *The Lewis Carroll Picture Book*), reprinted by Dover, New York, 1961, pp. 247-263.

LEROY F. MEYERS,
The Ohio State University.

*

*

*

MATHEMATICAL SWIFTIES

"Solutions to $\frac{\partial T}{\partial t} = \nabla^2 T + Q(x,y,z)$ are not easy to find", Tom insisted heatedly.

"The alternating harmonic series converges", Tom guessed conditionally.

M.S.K.

SOLUTIONS TO "TWO TIMELY PROBLEMS" (see page 7)

Both of these problems are as easy as can be, for one has only to make an attempt and he will be successful (barring, of course, errors in arithmetic). In the first problem one can obtain $6!$ sets of numbers, each of which will total 1980; while in the second problem there are $10!$ ways of placing the digits, but again each of these will yield the remainder 1980.

These problems are the 1980 versions of two similar problems sent to me many years ago by Leo Moser. The real problem is to explain how such an array and such a division can be found in the first place. This was part of the genius of Leo Moser.

HOWARD EVES,
University of Maine.

*

*

*

THE OLYMPIAD CORNER: 11

MURRAY S. KLAMKIN

The problems in this month's new Practice Set are all geometric and have appeared previously in a Hungarian, a Russian, and a Polish Mathematical Olympiad, respectively. They were translated into English by S.L. Greitzer.

PRACTICE SET 9

9-1, ABCD is a plane quadrilateral. A' is symmetric to A with respect to B; B' is symmetric to B with respect to C; C' is symmetric to C with respect to D; and D' is symmetric to D with respect to A. Construct quadrilateral ABCD given the points A' , B' , C' , D' .

9-2, Tangents to a circle from an external point O meet the circle at A and B. Chord AC is constructed parallel to OB, and secant OC is drawn, intersecting the circle at E. Prove that line AE bisects segment OB.

9-3, If two altitudes of a tetrahedron intersect, then the other two altitudes also intersect.

*

The problems in Practice Set 8, whose solutions appear below, were taken from some past Hungarian Mathematical Olympiads and were translated into English by Frank J. Papp (Associate Editor, *Mathematical Reviews*).

SOLUTIONS TO PRACTICE SET 8

8-1. At midnight a truck starts from city A and goes to city B ; at 2:40 a.m. a car starts along the same route from city B to city A . They pass at 4:00 a.m. The car arrives at its destination 40 minutes later than the truck. Having completed their business, they start for home and pass each other on the road at 2:00 p.m. Finally, they both arrive home at the same time. At what time did they arrive home?

Solution.

It will be helpful if we first draw a world-line graph of the motion (a plot of distance vs. time).

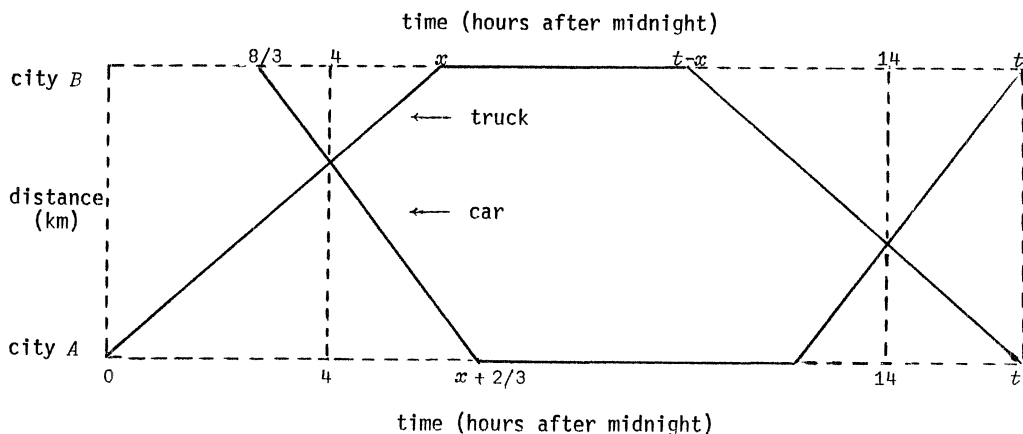

Suppose the truck arrives at city B at time $x > 4$ (all times are reckoned as hours after midnight); then the car, which leaves B at time $8/3$, arrives at A at time $x + 2/3$. Let v_c and v_t (km/hr) be the speeds (assumed constant) of the car and truck, respectively; then we have

$$(4 - 8/3)v_c = (x - 4)v_t \quad \text{and} \quad (x + 2/3 - 4)v_c = 4v_t.$$

Dividing corresponding members of these equations yields, after reduction, $(x - 6)(3x - 4) = 0$, from which $x = 6$ and then, from either equation, $v_c/v_t = 3/2$.

Now the car and truck both arrive home at time t if and only if $t - 6 < 14 < t$, that is, $14 < t < 20$, and

$$(14 - (t - 6))v_t = (t - 14)v_c.$$

Since $v_c/v_t = 3/2$, this equation yields $t = 16.4$.

The common time of arrival is 4:24 p.m.

8-2. Find all fourth-degree polynomials (with complex coefficients) with the property that the polynomial and its square each consist of exactly five terms.

Solution.

Let

$$P(x) \equiv Ax^4 + Bx^3 + Cx^2 + Dx + E, \quad ABCDE \neq 0 \quad (1)$$

be a polynomial with the desired property; then, for any nonzero constants m and n , the polynomial

$$mP(nx) = Amn^4x^4 + Emn^3x^3 + Cmn^2x^2 + Dmnx + Em \quad (2)$$

clearly has the same property. In particular, if $m = 1/E$ and n is any fourth root of E/A , then (2) reduces to the form

$$Q(x) \equiv x^4 + ax^3 + bx^2 + cx + 1, \quad abc \neq 0. \quad (3)$$

Conversely, if $Q(x)$ has the desired property, then so has $rQ(sx)$ for any nonzero constants r and s , and we can get a polynomial of the form (1) by setting

$$A = rs^4, \quad B = ars^3, \quad C = brs^2, \quad D = crs, \quad E = r. \quad (4)$$

Hence, to find all polynomials of the form (1) with the desired property, it is sufficient to find all polynomials of the form (3) with the property, then let r and s range over all nonzero numbers and use (4).

Since

$$\begin{aligned} \{Q(x)\}^2 &= x^8 + 2ax^7 + (a^2 + 2b)x^6 + 2(ab + c)x^5 + (b^2 + 2ca + 2)x^4 \\ &\quad + 2(a + bc)x^3 + (2b + c^2)x^2 + 2cx + 1, \end{aligned}$$

a necessary and sufficient condition is the vanishing of exactly four of the following five coefficients:

$$a^2 + 2b, \quad ab + c, \quad b^2 + 2ca + 2, \quad a + bc, \quad 2b + c^2.$$

Suppose $a^2 + 2b \neq 0$; then

$$ab + c = 0, \quad a + bc = 0, \quad 2b + c^2 = 0.$$

Multiplying the first of these equations by c and the second by a , we get $c^2 = a^2$, and then $2b + a^2 = 0$ from the third, a contradiction. A similar contradiction is obtained if $2b + c^2 \neq 0$. Suppose $ab + c \neq 0$; then

$$a^2 + 2b = 0, \quad 2b + c^2 = 0, \quad a + bc = 0.$$

Here we get $c^2 = a^2$ from the first two equations, and then

$$a + bc = 0 \implies a^2 + abc = 0 \implies c^2 + abc = 0 \implies c + ab = 0,$$

a contradiction. A similar contradiction results if $a + bc \neq 0$. Thus we must have

$$a^2 + 2b = 0, \quad 2b + c^2 = 0, \quad ab + c = 0, \quad a + bc = 0, \quad (5)$$

provided the solutions of (5) are such that $b^2 + 2ca + 2 \neq 0$. As before, $c^2 = a^2$ follows from the first two equations, and then

$$ab + c = 0 \implies c^2 = a^2b^2 \implies a^2 = a^2b^2 \implies b^2 = 1.$$

Finally, from the first two equations in (5), we get

$$b = \pm 1 \implies c^2 = a^2 = \mp 2. \quad (6)$$

Of the eight triples (a, b, c) defined by (6), only four satisfy all of (5); these are

$$(a, b, c) = (i\sqrt{2}, 1, -i\sqrt{2}), (-i\sqrt{2}, 1, i\sqrt{2}), (\sqrt{2}, -1, \sqrt{2}), (-\sqrt{2}, -1, -\sqrt{2}),$$

and for each of these $b^2 + 2ca + 2 = 7$.

Thus there are exactly four polynomials of the form (3) having the desired property. They are listed below.

$Q(x)$	$\{Q(x)\}^2$
$x^4 + i\sqrt{2}x^3 + x^2 - i\sqrt{2}x + 1$	$x^8 + 2i\sqrt{2}x^7 + 7x^4 - 2i\sqrt{2}x + 1$
$x^4 - i\sqrt{2}x^3 + x^2 + i\sqrt{2}x + 1$	$x^8 - 2i\sqrt{2}x^7 + 7x^4 + 2i\sqrt{2}x + 1$
$x^4 + \sqrt{2}x^3 - x^2 + \sqrt{2}x + 1$	$x^8 + 2\sqrt{2}x^7 + 7x^4 + 2\sqrt{2}x + 1$
$x^4 - \sqrt{2}x^3 - x^2 - \sqrt{2}x + 1$	$x^8 - 2\sqrt{2}x^7 + 7x^4 - 2\sqrt{2}x + 1$

8-3. Let n be a given natural number. Find nonnegative integers k and l so that their sum differs from n by a natural number and so that the following expression is as large as possible:

$$\frac{k}{k+l} + \frac{n-k}{n-(k+l)}.$$

Solution.

The nonnegative integers k and l must not both vanish and their sum must not equal n . Let S be the sum given in the proposal. We have $S = 2$ for $l = 0$ and $0 < k \neq n$.

We now assume that $l > 0$ is fixed and let $u = k + l$, so that $0 < u \neq n$. The given sum S can be written

$$S = 1 - \frac{l}{k+l} + 1 + \frac{l}{n-(k+l)} = 2 + lf(u),$$

where

$$f(u) = \frac{1}{n-u} - \frac{1}{u}, \quad 0 < u \neq n.$$

It is clear that f is strictly increasing for all $u < n$, and that it is negative and strictly increasing for all $u > n$. We now consider two cases:

(a) If $n=1$, then f is defined only for $u > n$. Hence $f(u)$ is negative for all u and increases to 0, and S increases to 2, as $u \rightarrow \infty$. But the limiting value $S=2$ is never attained (except, as we have seen, when $l=0$).

(b) If $n > 1$ (and $l > 0$ is still fixed), then $f(u)$ attains its maximum value $(n-2)/(n-1)$ when $u = n-1$. With u fixed at this value, we now liberate l and allow it to take any of the values $1, 2, \dots, n-1$. We see that S , unless it is constant (when $n=2$), then increases with l and attains its maximum value n when $l = n-1$ (and $k=0$).

To recapitulate:

if $n=1$, $S_{\max} = 2$ for $l=0$ and $k > 1$;

if $n=2$, $S_{\max} = 2$ for $l=1$, $k=0$ and for $l=0$, $0 < k \neq 2$;

if $n \geq 3$, $S_{\max} = n$ for $l = n-1$, $k=0$.

Editor's note. All communications about this column should be sent to Professor M.S. Klamkin, Department of Mathematics, University of Alberta, Edmonton, Alberta, Canada T6G 2G1.

*

*

*

PROBLEMS -- PROBLÈMES

Problem proposals and solutions should be sent to the editor, whose address appears on the front page of this issue. Proposals should, whenever possible, be accompanied by a solution, references, and other insights which are likely to be of help to the editor. An asterisk () after a number indicates a problem submitted without a solution.*

Original problems are particularly sought. But other interesting problems may also be acceptable provided they are not too well known and references are given as to their provenance. Ordinarily, if the originator of a problem can be located, it should not be submitted by somebody else without his permission.

To facilitate their consideration, your solutions, typewritten or neatly handwritten on signed, separate sheets, should preferably be mailed to the editor before April 1, 1980, although solutions received after that date will also be considered until the time when a solution is published.

501, *Proposed by J.A.H. Hunter, Toronto, Ontario.*

For the second time in less than a year, Canadians are undergoing the throes of a national election. In the alphametic

$$\begin{array}{r} \text{N O} \\ \text{F O O L'S} \\ \text{A L O N E} \\ \hline \text{A T} \\ \text{O T T A W A} \end{array}$$

you won't be sure about the FOOLS (until after the election), but what's the unique value of OTTAWA?

502, *Proposed by Basil C. Rennie, James Cook University of North Queensland, Australia.*

Given $n > 3$ points in the plane, no three collinear, we are interested in "triangulating" their convex hull, that is, in covering it with nonoverlapping triangles, each having three of the given points as vertices.

(a) For a fixed set of points, there are several ways of triangulating. Do they all give the same number of triangles?

(b) For fixed n , different sets of n points may be triangulated with different numbers of triangles. What bounds can be given for the number of triangles?

503, *Proposed by Meir Katchalski, Technion, Israel and Andy Liu, University of Regina.*

Let the north-east corner of a compact set S in the plane be the point (a,b) such that

$$a = \max \{x \mid (x,y) \in S\} \quad \text{and} \quad b = \max \{y \mid (a,y) \in S\}.$$

Let F be a family of at least two compact convex sets in the plane with nonempty intersection. Prove that there exist two sets in F such that the north-east corner of their intersection coincides with the north-east corner of the intersection of the entire family.

504, *Proposed by Leon Bankoff, Los Angeles, California and Jack Garfunkel, Flushing, N.Y.*

Given is a triangle ABC and its circumcircle. Find a Euclidean construction for a point J inside the triangle such that, when the chords AD, BE, CF are all drawn through J, then triangle DEF is equilateral.

505, *Proposed by Bruce King, Western Connecticut State College and Sidney Fenner, Bronx Community College.*

Let

$$F_1 = F_2 = 1, \quad F_n = F_{n-1} + F_{n-2} \quad \text{for } n > 2$$

and

$$G_1 = 1, \quad G_n = 2^{n-1} - G_{n-1} \quad \text{for } n > 1.$$

Show that (a) $F_n \leq G_n$ for each n and (b) $\lim_{n \rightarrow \infty} F_n / G_n = 0$.

506, Proposed by M.S. Klamkin, University of Alberta.

It is known from an earlier problem in this journal [1975: 28] that if a, b, c are the sides of a triangle, then so are $1/(b+c), 1/(c+a), 1/(a+b)$. Show more generally that if a_1, a_2, \dots, a_n are the sides of a polygon then, for $k=1, 2, \dots, n$,

$$\frac{n+1}{S-a_k} \geq \sum_{\substack{i=1 \\ i \neq k}}^n \frac{1}{S-a_i} \geq \frac{(n-1)^2}{(2n-3)(S-a_k)},$$

where $S = a_1 + a_2 + \dots + a_n$.

507* Proposed by Rufus Isaacs, Baltimore, Maryland.

The sequence of numbers (t_1, t_2, \dots, t_n) is symmetric in that $t_k = t_{n+1-k}$ for $k=1, 2, \dots, n$. The sequences (x_k) and (y_k) are defined by

$$x_0 = 0, \quad x_1 = 1; \quad x_{k+1} = t_k x_k + x_{k-1}, \quad k = 1, 2, \dots, n.$$

$$y_0 = 1, \quad y_1 = 0; \quad y_{k+1} = t_k y_k + y_{k-1},$$

Show that $x_n = y_{n+1}$.

508, Proposed by Kenneth M. Wilke, Topeka, Kansas.

Problem 24 in W. Sierpiński's *250 Problems in Number Theory* (American Elsevier, 1970) asks for an infinite set of pairs (x, y) of positive integers such that $x^x | y^y$ but $x | y$. The answer given is $x = 2^k, y = 2p$, where $k > 1$ is an integer and $p > k \cdot 2^{k-1}$ is a prime. Show that there is an infinite set of pairs (x, y) with the same property in which x contains an odd factor.

509, Proposed by Charles W. Trigg, San Diego, California.

Is there any system of notation in which there is a repdigit aa such that

$$(aa)^2 = cedd, \quad \text{with } c = a-1 \quad \text{and} \quad d = c-1?$$

510, Proposed by Gali Salvatore, Perkins, Québec.

There is only one integer n for which the expression

$$E(n) \equiv \frac{12n^3 - 5n^2 - 251n + 389}{6n^2 - 37n + 45}$$

is an integer. Find this value of n and show there are no others.

*

*

*

S O L U T I O N S

No problem is ever permanently closed. The editor will always be pleased to consider for publication new solutions or new insights on past problem.

418. [1979: 48] *Proposed by James Gary Propp, student, Harvard College.*

Given a sequence S consisting of n consecutive natural numbers with $n \geq 3$, two players take turns striking terms from S until only two terms a, b remain. If a and b are relatively prime, then the player with the first move wins; otherwise, his opponent does. For what values of n does the first player have a winning strategy, regardless of S ?

Solution and comment by Leroy F. Meyers, The Ohio State University.

(a) If $n = 2k + 1$, then the first player (call him A) has a winning strategy for any $k \geq 1$. He mentally partitions S into k disjoint pairs of consecutive integers, and an "odd" integer (which may be even). He first strikes the "odd" integer. After any move of the second player (call him B), A strikes the other integer in the pair containing the integer struck by B . After the last move, two consecutive integers remain, and these are relatively prime.

(b) If n is even, we show that A has a winning strategy if (i) $n = 4$ or 6 , or (ii) $n = 8$ or 10 and S contains only one odd multiple of 3 ; and B has a winning strategy otherwise.

We will say that the players follow a *normal pattern* as long as A strikes only even numbers and B strikes only odd numbers. If A is first to break the pattern, then B wins by continuing to strike odd numbers as long as possible; two even numbers (obviously not relatively prime) will remain. Thus we may assume that A strikes only even numbers, unless B is first to break the pattern.

If S contains (at least) two odd multiples of 3 (which cannot occur if $n = 4$ or 6 , may but need not occur if $n = 8$ or 10 , and must occur if $n \geq 12$), then B wins by mentally marking two such multiples and striking only the other odd numbers, but breaking the pattern by striking the last even number at the last move (unless A has already broken the pattern). The two odd multiples of 3 , which are obviously not relatively prime, remain.

Suppose S contains at most one odd multiple of 3, so that $4 \leq n \leq 10$. Then the odd numbers in S are pairwise relatively prime. Here B loses by being first to break the pattern, since A can then continue to strike even numbers as long as possible, and two relatively prime odd numbers will remain. Hence we may assume that neither player breaks the pattern. If there is an even number in S which is relatively prime to all the odd numbers in S , then A wins by mentally marking such an even number and never striking it (unless B breaks the pattern). If $n = 4$, at least one of the two even numbers in S is not divisible by 3. If $n = 6$, at least one of the three even numbers is divisible by neither 3 nor 5. If $n = 8$ or 10, then at most two of the even numbers are divisible by 3 and at most one each by 5 and 7. Hence, if $n = 10$, at least one of the five even numbers in S is divisible by none of 3, 5, 7. If $n = 8$ and each of the four even numbers is divisible by at least one of 3, 5, 7, then the largest and smallest of the even numbers must be divisible by 3 and one of the other two even numbers must be divisible by 7; but then no odd number in S is divisible by 7. Hence in all of these cases there is a markable number, and so A has a winning strategy.

Comment. Similar winning strategies can be worked out when the winning conditions are reversed, that is, when B wins if the two remaining numbers are relatively prime and A wins if they are not.

(a) If $n = 2k$, then B has a winning strategy for every $k > 1$. He mentally partitions S into k disjoint pairs of consecutive integers, and, as a response to any move by A , strikes the other integer in the pair from which A has struck one number. Two consecutive integers, obviously relatively prime, remain at the end of the game.

(b) If n is odd, we show that B has a winning strategy if S contains an excess of odd numbers and (i) $n = 3$ or 5 or (ii) $n = 7$ or 9 and S contains only one odd multiple of 3; and A has a winning strategy otherwise.

If there is an excess of even numbers, A wins by striking, if possible, an odd number at each move. At the end of the game, all odd numbers are used up and two even integers, obviously not relatively prime, remain.

Suppose, then, that there is an excess of odd numbers. The *normal pattern*, this time, is for A to strike only odd numbers and B only even numbers. B cannot be first to break the pattern, since otherwise A , by striking odd numbers whenever possible, will leave two even numbers at the end and win. If S contains at least two odd multiples of 3 (this cannot occur if $n = 3$ or 5, *may* occur if $n = 7$ or 9, and must occur if $n \geq 11$), then A wins by striking all odd numbers except two odd multiples of 3, and then at the last move striking the only remaining even number.

If there is at most one odd multiple of 3, then B wins by striking whenever possible even numbers which are not relatively prime to all the remaining odd numbers.

Also solved by MICHAEL W. ECKER, Pennsylvania State University, Worthington Scranton campus; FRIEND H. KIERSTEAD, JR., Cuyahoga Falls, Ohio; and the proposer (partial solution).

*

*

*

419, [1979: 48] Proposed by G. Ramanajah, Madras Institute of Technology, India.

A variable point P describes the ellipse $x^2/a^2 + y^2/b^2 = 1$. Does it make sense to speak of "the mean distance of P from a focus S "? If so, what is this mean distance?

Composite solution consisting mainly of information extracted from Stein [1] and from the solutions received.

It will be convenient to consider the ellipse, of semimajor and semiminor axes a and b , and eccentricity e , as the orbit of a planet P about the sun S . With this interpretation, the expression "mean distance" certainly makes sense. Kepler's third law, which gives the period T of a satellite whose orbit is an ellipse, says that *the square of the period is proportional to the cube of the mean distance*. By "mean distance," Kepler meant the radius of the large circle which carries the Copernican epicycles that approximate the planet's orbit; in other words, the radius of the auxiliary circle of the ellipse, or its semimajor axis a . But in modern expositions, "mean distance" is usually defined as the average of the greatest and the least distances from the planet to the sun. Since this is

$$\frac{1}{2}\{(a+ae) + (a-ae)\} = a,$$

the modern definition agrees with Kepler's.

However, one who has studied calculus, and for whom "ellipse" and "focus" have no astronomical overtones, would probably interpret "mean distance" as meaning *the average distance from P to S throughout the orbit of P* . This requires taking the average of an uncountable set of distances. For a finite set of numbers $\{r_1, r_2, \dots, r_n\}$, the average (or mean) is

$$A_n = \frac{1}{n}(r_1 + r_2 + \dots + r_n);$$

and for a countable sequence the definition $\lim_{n \rightarrow \infty} A_n$ for the average is both natural and

inescapable. But for uncountable sets of numbers there is no unique way of defining the average (see Crux 376 [1979: 143] for a similar situation). However, the integration process furnishes us with several natural ways of defining "mean distance", and some of these will be explored below.

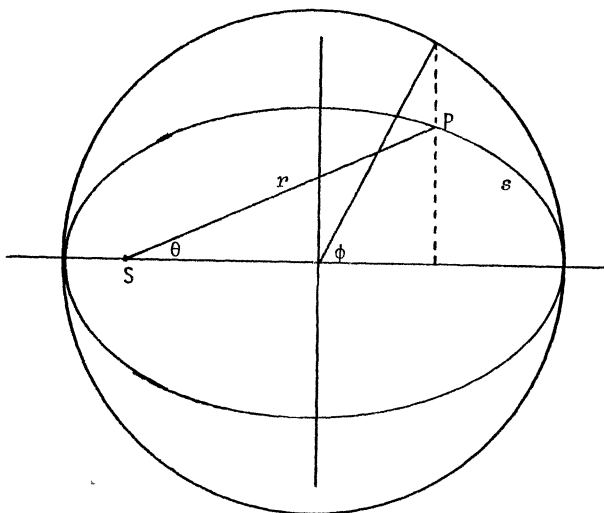

Place the pole of a polar coordinate system at the focus S and the polar axis along the major axis of the ellipse. If P is the point (r, θ) , as shown in the figure, then

$$r = \frac{a(1 - e^2)}{1 - e \cos \theta}.$$

Astronomers call θ the *true anomaly*.

(a) The mean value of r with respect to θ is defined to be

$$\bar{r} = \frac{1}{2\pi} \int_0^{2\pi} r \, d\theta = \frac{1}{2\pi} \int_0^{2\pi} \frac{a(1 - e^2)}{1 - e \cos \theta} \, d\theta = a \sqrt{1 - e^2} = b.$$

(b) Let s be the arc length from the aphelion to the position of P , and let L be the arc length of the entire orbit. The mean value of r with respect to s is defined to be

$$\bar{r} = \frac{1}{L} \int_0^L r \, ds = a,$$

which agrees with Kepler's mean distance. (See [1] for details of the calculation.)

(c) If t is the time required to reach position P from the aphelion, and if T is the period (duration of one revolution), then the mean value of r with respect to t is defined by

$$\bar{r} = \frac{1}{T} \int_0^T r dt = a(1 + \frac{1}{2}e^2).$$

(See [1] for details.) The fact that the time average is larger than the other two reflects the fact that the planet spends more time near its aphelion, where its velocity is lower, than near its perihelion.

(d) For this final example, we use a rectangular coordinate system and the usual parametric equations for the ellipse,

$$x = a \cos \phi, \quad y = b \sin \phi,$$

where ϕ is the eccentric angle (called *eccentric anomaly* by astronomers). The mean value of r with respect to ϕ is defined by

$$\bar{r} = \frac{1}{2\pi} \int_0^{2\pi} r d\phi = \frac{1}{2\pi} \int_0^{2\pi} a(1 + e \cos \phi) d\phi = a,$$

which also agrees with Kepler's value.

Obviously, there are other ways of defining "mean distance of P from S." Whether they are more or less "natural" than those given above is largely a matter of opinion.

Solutions were received from JORDI DOU, Escola Tecnica Superior Arquitectura de Barcelona, Spain; FRIEND H. KIERSTEAD, JR., Cuyahoga Falls, Ohio; and the proposer.

REFERENCE

1. Sherman K. Stein, "'Mean Distance' in Kepler's Third Law," *Mathematics Magazine* 50 (May 1977) 160-162.

*

*

*

420, [1979: 48] Proposed by J.A. Spencer, Magrath, Alberta.

Given an angle AOB, find an economical Euclidean construction that will quadriseect the angle. "Economical" means here using the smallest possible number of Euclidean operations: setting a compass, striking an arc, drawing a line.

Solution by the proposer.

Five Euclidean operations suffice: striking two arcs (circles) and drawing three lines. No compass setting is required since the same arbitrary fixed compass span is used throughout (that is, we can assume we have a rusty compass).

The five steps are listed below.
The proof of the construction is obvious and not given.

1. Produce BO (see figure).
2. Describe circle (O) to meet OA and BO produced in C and P , respectively.
3. Describe circle (P) .
4. Join CP and produce the line to meet circle (P) again at E .
5. Join EO and produce the line to H .

Then OH is the required
quadriselector of angle AOB .

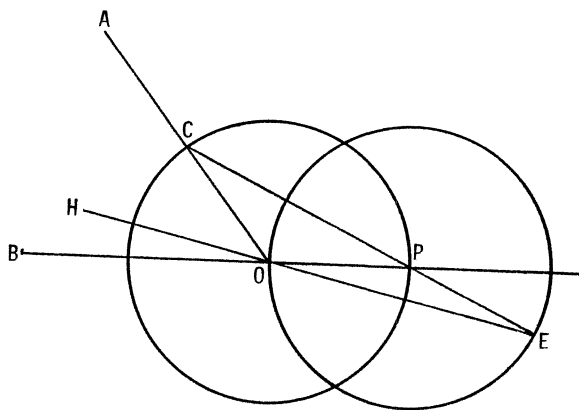

Also solved by CLAYTON W. DODGE, University of Maine at Orono; JACK GARFUNKEL, Flushing, N.Y.; ROBERT S. JOHNSON, Montréal, Québec; FRIEND H. KIERSTEAD, JR., Cuyahoga Falls, Ohio; MURRAY S. KLAMKIN, University of Alberta; and CHARLES W. TRIGG, San Diego, California.

Editor's comment.

In assessing the solutions, the editor interpreted the three Euclidean operations in the following way, which seemed to follow most naturally from the wording of the problem:

Setting a compass: adjusting the span of the compass.

Striking an arc: putting the compass in place and describing an arc (or circle).

Drawing a line: lining up a straightedge with two points and drawing the line joining them.

Furthermore, the editor assumed (as did all solvers) that the compass was a modern rigid one (though not necessarily rusty), not a true Euclidean compass, which must be assumed to collapse when not in use. With a true Euclidean compass, all solvers' counts would have been higher.

With these interpretations, we have a simplified set of rules for the science of *geometrography*, developed in 1907 by Émile Lemoine for quantitatively comparing one construction with another. For a more adequate but more elaborate version, see the editor's comment following Crux 288 [1978: 138] and the Howard Eves reference given there.

Editor's comment.

Our featured solver gave detailed solutions to all four alphametics, but the editor decided to save space by giving only the easiest one. Solutions to alphametics may be fun to find but, unless the answer falls out easily, are tedious to write up (and even more tedious to read). Perhaps that is why most solvers (and even many proposers) send in only answers to such problems.

* * *

422. [1979: 76] *Proposed by Dan Pedoe, University of Minnesota.*

The lines l and m are the parallel edges of a strip of paper and P_1, Q_1 are points on l and m , respectively (see figure). Fold P_1Q_1 along l and crease, obtaining P_1Q_2 as the crease. Fold P_1Q_2 along m and crease, obtaining P_2Q_2 . Fold P_2Q_2 along l and crease, obtaining P_2Q_3 . If the process is continued indefinitely, show that the triangle $P_n P_{n+1} Q_{n+1}$ tends towards an equilateral triangle.

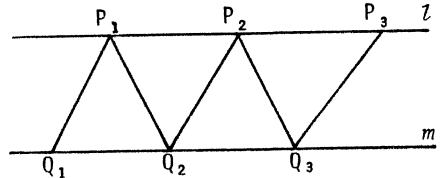

(I don't know the origin of this problem. A student asked me to prove it many years ago.)

I. *Solution by Jeremy D. Primer, student, Columbia H.S., Maplewood, New Jersey.*

Let $\alpha_0, 0 < \alpha_0 < \pi$, be the angle that P_1Q_1 makes with line m on the side on which the folds are made; and let $\alpha_1, \alpha_2, \dots$ be the angles, and $\Delta_1, \Delta_2, \dots$ the triangles, formed by the successive creases, as shown in the figure.

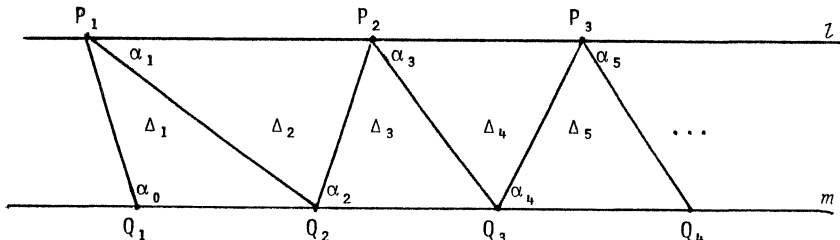

Since l is parallel to m and the adjacent angles formed by a crease are equal, the angles of Δ_1 are $\alpha_0, \alpha_1, \alpha_1$, and it follows by induction that the angles of Δ_n are $\alpha_{n-1}, \alpha_n, \alpha_n$. Hence we have the difference equation

$$\alpha_{n-1} + 2\alpha_n = \pi,$$

whose solution is

$$\alpha_n = \frac{\pi}{3} + \left(-\frac{1}{2}\right)^n \left(\alpha_0 - \frac{\pi}{3}\right), \quad n = 1, 2, 3, \dots$$

Since $\lim_{n \rightarrow \infty} \alpha_n = \pi/3$, we can say, loosely speaking, that Δ_n "tends towards" an equilateral triangle as $n \rightarrow \infty$, because each of its angles approaches $\pi/3$.

II. *Adapted from a comment by Jordi Dou, Escola Tecnica Superior Arquitectura de Barcelona, Spain.*

Suppose l and m are not parallel but intersect, forming an angle β , $0 < \beta < \pi$. We proceed as in, and use the notation of, solution I. If the folds are made on the side of P_1Q_1 on which l and m converge, then (make a figure!) Δ_1 has angles α_0 , α_1 , $\alpha_1 + \beta$, and Δ_n has angles α_{n-1} , α_n , $\alpha_n + \beta$. This leads to the difference equation

$$\alpha_{n-1} + 2\alpha_n = \pi - \beta,$$

with solution

$$\alpha_n = \frac{\pi - \beta}{3} + \left(-\frac{1}{2}\right)^n \left(\alpha_0 - \frac{\pi - \beta}{3}\right), \quad n = 1, 2, 3, \dots$$

Since $\lim_{n \rightarrow \infty} \alpha_n = (\pi - \beta)/3$, Δ_n "tends towards" an isosceles triangle with angles

$$\frac{\pi - \beta}{3}, \quad \frac{\pi - \beta}{3}, \quad \frac{\pi + 2\beta}{3}.$$

Proceeding similarly, we would find that when the folds are made on the side of P_1Q_1 on which l and m diverge, then Δ_n "tends towards" an isosceles triangle with angles

$$\frac{\pi + \beta}{3}, \quad \frac{\pi + \beta}{3}, \quad \frac{\pi - 2\beta}{3}.$$

Also solved by HAYO AHLBURG, Benidorm, Alicante, Spain; CLAYTON W. DODGE, University of Maine at Orono; JORDI DOU, Escola Tecnica Superior Arquitectura de Barcelona, Spain; MICHAEL W. ECKER, Pennsylvania State University, Worthington Scranton Campus; ROLAND H. EDDY, Memorial University of Newfoundland; G.C. GIRI, Research Scholar, Indian Institute of Technology, Kharagpur, India; ALLAN WM. JOHNSON JR., Washington, D.C.; FRIEND H. KIERSTEAD, JR., Cuyahoga Falls, Ohio; KESIRAJU SATYANARAYANA, Gagan Mahal Colony, Hyderabad, India; DAN SOKOLOWSKY, Antioch College, Yellow Springs, Ohio; and the proposer.

Editor's comment.

Primer noted that an equivalent problem appeared in the October, 1978 issue of *The Mathematics Student*.

Solution I involved setting up (by induction) and solving (by standard techniques) a difference equation. This, or something equivalent, is required for a satisfactory solution. Several solvers contented themselves with a liberal prin-

king of "three little dots", with the help of which they were able to "see" the answer. But the name of this game is *mathematics*, not reading tea leaves. Solvers should never take a heuristic argument for a valid proof, on pain of remaining among the also-rans. A proof is a proof is a proof.

*

*

*

423. [1979: 76] Proposed by Jack Garfunkel, Forest Hills H.S., Flushing, N.Y.

In a triangle ABC whose circumcircle has unit diameter, let m_a and t_a denote the lengths of the median and the internal angle bisector to side a , respectively. Prove that

$$t_a \leq \cos^2 \frac{A}{2} \cos \frac{B-C}{2} \leq m_a.$$

Solution by Jordi Dou, Escola Tecnica Superior Arquitectura de Barcelona, Spain.

Let α, β, γ be the angles of triangle ABC. Draw through the circumcentre O diameter $DD' \perp BC$, meeting BC in M (see figure).

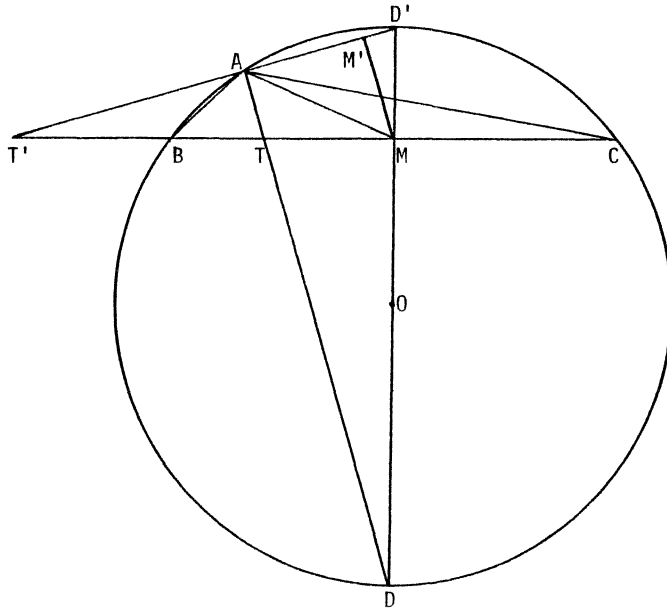

We assume for now that $\beta \neq \gamma$. If we draw $MM' \perp AD'$, then clearly $MM' < AM$. Now suppose the internal bisector AD and the external bisector AD' of angle A meet BC

in T and T', respectively. Then T and T' lie on the same side of M, and hence $AT < MM'$. Since $AT = t_\alpha$ and $AM = m_\alpha$, we have so far proved the double strict inequality in

$$t_\alpha \leq MM' \leq m_\alpha. \quad (1)$$

And it is clear that equality holds on both sides of (1) if and only if $\beta = \gamma$.

If $\alpha \geq \pi/2$ (as in our figure), we have

$$MD' = OD' - OM = \frac{1}{2} - \frac{1}{2} \cos(\pi - \alpha) = \frac{1}{2} + \frac{1}{2} \cos \alpha = \cos^2 \frac{\alpha}{2};$$

and if $\alpha < \pi/2$, then

$$MD' = OD' + OM = \frac{1}{2} + \frac{1}{2} \cos \alpha = \cos^2 \frac{\alpha}{2}.$$

Now

$$\angle M'MD' = \angle ADD' = \frac{1}{2} \text{arc } AD' = \frac{1}{2} |\beta - \gamma|;$$

hence

$$MM' = MD' \cos \frac{\beta - \gamma}{2} = \cos^2 \frac{\alpha}{2} \cos \frac{\beta - \gamma}{2},$$

and the desired inequality follows from (1).

And also solved by HAYO AHLBURG, Benidorm, Alicante, Spain; W.J. BLUNDON, Memorial University of Newfoundland; ROLAND H. EDDY, Memorial University of Newfoundland; G.C. GIRI, Research Scholar, Indian Institute of Technology, Kharagpur, India; FRIEND H. KIERSTEAD, JR., Cuyahoga Falls, Ohio; M.S. KLAMKIN, University of Alberta; KESIRAJU SATYANARAYANA, Gagan Mahal Colony, Hyderabad, India; DAN SOKOLOWSKY, Antioch College, Yellow Springs, Ohio; JOHN A. WINTERINK, Albuquerque Technical Vocational Institute, Albuquerque, New Mexico; and the proposer.

Editor's comment.

Klamkin noted that an inequality equivalent to our median inequality (the right inequality in our problem) was proposed by G. Tsintsifas (*American Mathematical Monthly*, 82 (1975) 523-524).

*

*

*

424, [1979: 77] Proposed by J. Walter Lynch, Georgia Southern College, Statesboro, Georgia.

Is it possible to make a convex object out of homogeneous material that will be at rest in exactly one position? (For example, a cube would be at rest in 6 positions, a hemisphere in two, a sphere in infinitely many.)

I. Solution by Michael Goldberg, Washington, D.C.

This problem is a simplified version of Problem 66-12 which appeared in *SIAM Review* in 1966. There it was required to find a homogeneous convex polyhedron

which was stable on only one face. The solution of that problem appeared later in [1]. A simplified version of my solution of that problem will serve for the present problem, where the solid is not required to be polyhedral.

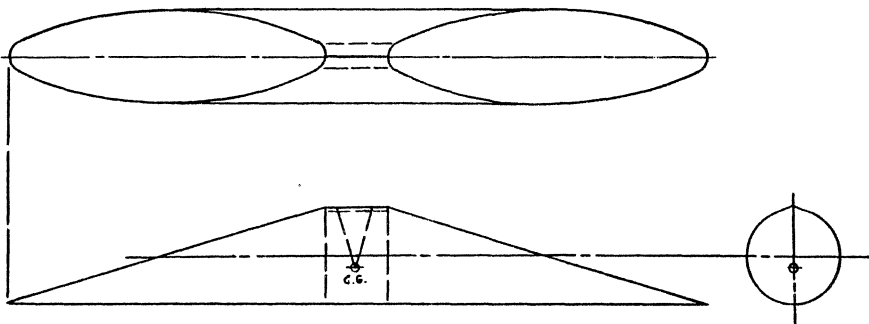

The solid is approximately a doubly truncated circular cylinder, several views of which are shown in the figure. The distance between the center of gravity (C.G.) and the axis of the cylinder is one-fourth of the radius of the cylinder. Since the perpendicular from the C.G. to an elliptical face should not meet that face, a small cylindrical section is inserted and a ridge is added at the top so that this perpendicular meets the ridge. The solid can only be in unstable equilibrium when resting on this ridge, and it will obviously be in stable equilibrium (at rest) in only one position.

II. *"Solution" by an anonymous colleague of the proposer.*

The answer is NO. For if it were possible to make such a body, the toy manufacturers would long since have utilized it.

Also solved by BASIL C. RENNIE, James Cook University of North Queensland, Australia. Comments were received from DAVID HAMMER, Los Gatos, California; ROBERT S. JOHNSON, Montréal, Québec; M.S. KLAMKIN, University of Alberta; and C.S. OGILVY, Mamaroneck, New York.

Editor's comment.

Hammer referred to Shephard [2] who gives, as an answer to the polyhedron problem, a polyhedron of 21 faces, consisting of a doubly truncated 19-sided convex prism, and investigates several related questions. Klamkin noted that [1] contains an improved solution by R.K. Guy to the polyhedron problem, consisting of a doubly truncated 17-sided convex prism, making it an enneadecahedron (19 faces). The

conjecture is there made that 19 is the least number of faces such a solid can have, and several related questions are raised there, as well as in [3]. Ogilvy referred to his book [4], where he describes Guy's enneadecahedron.

Rennie showed that one answer to our own problem is a solid made from rigid homogeneous material in the shape of the region defined by

$$x^2 + \left(y + \frac{cx^2}{b^2} \right)^2 + \frac{z^2}{b^2} \leq 1,$$

where $0 < c < \frac{1}{2}$ and $b > \sqrt{2}$. The solid is convex, its centre of gravity is at $(0, -c/5, 0)$, and, when placed on a table, has only one stable position: when the point $(0, -1, 0)$ is on the table. Rennie ends his solution with the following advice: "Those thinking of tackling the problem experimentally with scrap brass in the home workshop might try soldering two conical caps on a sphere, not opposite each other."

REFERENCES

1. Problem 66-12, "Stability of Polyhedra", proposed by J.H. Conway and R.K. Guy, solutions by Michael Goldberg and R.K. Guy, *SIAM Review*, 11 (January 1969) 78-82.
2. G.C. Shephard, "Twenty Problems on Convex Polyhedra, Part II", Problem XVI, *The Mathematical Gazette*, 52 (1968) 364-365.
3. Problem 66-13, "A Double Tipping Tetrahedron", proposed by A. Héppes, with solution by the proposer, *SIAM Review*, 11 (1968) 599-600.
4. C.S. Ogilvy, *Tomorrow's Math*, Oxford University Press, New York, 1972, pp. 76-77.

*

*

*

425, [1979: 77] Proposed by Gali Salvatore, Ferkins, Québec.

Let x_1, x_2, \dots, x_n be the zeros of the polynomial

$$P(x) = x^n + ax^{n-1} + a^{n-1}x + 1, \quad n \geq 3$$

and consider the sum

$$\sum_{k=1}^n \frac{x_k + 2}{x_k - 1}.$$

Find all values of a and n for which this sum is defined and equal to $n-3$.

Solution by Viktors Linis, University of Ottawa.

The given sum is defined if and only if $P(1) \neq 0$, that is, if and only if

$$a^{n-1} + a + 2 \neq 0. \tag{1}$$

The logarithmic derivative of

$$P(x) = \prod_{k=1}^n (x - x_k) \quad \text{is} \quad \frac{P'(x)}{P(x)} = \sum_{k=1}^n \frac{1}{x - x_k};$$

hence

$$\sum_{k=1}^n \frac{x_k + 2}{x_k - 1} = \sum_{k=1}^n \left(1 + \frac{3}{x_k - 1} \right) = n - 3 \frac{P'(1)}{P(1)},$$

and this equals $n - 3$ if and only if $P(1) = P'(1)$, that is,

$$a^{n-1} + a + 2 = n + a(n-1) + a^{n-1},$$

an equation equivalent to $(a+1)(n-2) = 0$. Since $n \geq 3$, we must have $a = -1$, and then (1) requires n to be odd.

The required answer is $a = -1$ and $n = 2m + 1$, $m = 1, 2, 3, \dots$.

Also solved by G.C. GIRI, Research Scholar, Indian Institute of Technology, Kharagpur, India; M.S. KLAMKIN, University of Alberta; LEROY F. MEYERS, The Ohio State University; JEREMY D. PRIMER, student, Columbia H.S., Maplewood, N.J.; KESIRAJU SATYANARAYANA, Gagan Mahal Colony, Hyderabad, India; DAVID R. STONE, Georgia Southern College, Statesboro, Georgia; and the proposer.

* * *

426. [1979: 77] Proposed by Charles W. Trigg, San Diego, California.

There are two positive integers less than 10^{10} for each of which

- i) its digits are all alike;
- ii) its square has a digit sum of 37.

Find them and show that there are no others.

Solution by Allan Wm. Johnson Jr., Washington, D.C.

Let R_n be the n -digit repunit $111\dots 1$; then the numbers we are seeking are of the form $x = dR_n$, where d is a nonzero digit. Since the smallest integer with a digit sum of 37 is 19999, and $\sqrt{19999} > 141$, we must have $n \geq 3$. Casting out nines from x^2 gives

$$x^2 \equiv 37 \equiv 1 \pmod{9}, \tag{1}$$

which implies that $d \neq 3, 6, \text{ or } 9$. Now (1) holds only if $x \equiv \pm 1 \pmod{9}$, and casting out nines from x yields

$$dn \equiv \pm 1 \pmod{9}. \tag{2}$$

With the restrictions already noted for d and n , the solutions of (2) for $n < 9$ are

$$(d, n) = (2, 5), (4, 7), (7, 4), (8, 8)$$

and

$$(d, n) = (1, 8), (2, 4), (5, 7), (7, 5).$$

Only when $(d, n) = (2, 4)$ or $(7, 4)$ does the corresponding $x = dR_n$ have a square with digit sum 37:

$$2222^2 = 4937284,$$

$$7777^2 = 60481729.$$

For $n \geq 9$, there is no $x = dR_n$ such that x^2 has a digit sum of 37 for, with each allowable value of d , the last nine digits of x^2 have a sum already exceeding 37, as can be seen from the following list of congruences modulo 10^9 :

$$d = 1 \implies x^2 = (R_n)^2 \equiv 987654321,$$

$$d = 2 \implies x^2 = (2R_n)^2 \equiv 950617284,$$

$$d = 4 \implies x^2 = (4R_n)^2 \equiv 802469136,$$

$$d = 5 \implies x^2 = (5R_n)^2 \equiv 691358025,$$

$$d = 7 \implies x^2 = (7R_n)^2 \equiv 395061729,$$

$$d = 8 \implies x^2 = (8R_n)^2 \equiv 209876544.$$

This shows that the phrase "less than 10^{10} " can be dropped from the proposal without affecting the answers.

Also solved by HAYO AHLBURG, Benidorm, Alicante, Spain; CLAYTON W. DODGE, University of Maine at Orono; MICHAEL W. ECKER, Pennsylvania State University, Worthington Scranton Campus; ROBERT S. JOHNSON, Montréal, Québec; FRIEND H. KIERSTEAD, JR., Cuyahoga Falls, Ohio; J.A. McCALLUM, Medicine Hat, Alberta; HERMAN NYON, Paramaribo, Surinam; JEREMY D. PRIMER, student, Columbia H.S., Maplewood, N.J.; DAVID R. STONE, Georgia Southern College, Statesboro, Georgia; KENNETH M. WILKE, Topeka, Kansas; and the proposer.

*

*

*

427. [1979: 77] Proposed by G.P. Henderson, Campbellcroft, Ontario.

A corridor of width a intersects a corridor of width b to form an "L". A rectangular plate is to be taken along one corridor, around the corner and along the other corridor with the plate being kept in a horizontal plane. Among all the plates for which this is possible, find those of maximum area.

I. Solution by Michael Goldberg, Washington, D.C.

A rectangular plate of dimensions $a \times b$ can be translated along one corridor until it reaches the corner, and then translated in the perpendicular direction along the other corridor. Of all the rectangular plates which can get around the corner by translations alone, the one just described clearly has maximum area, which is equal to ab .

Let ABCD be a rectangular plate which can enter either corridor, that is, such that its width $BC \leq \min\{a, b\}$. Then such a plate is one of maximum area which can be

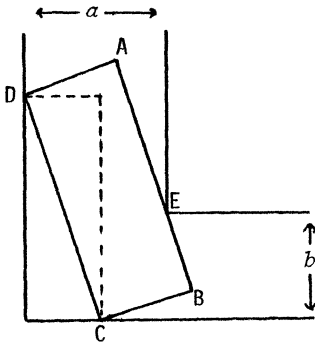

Figure 1

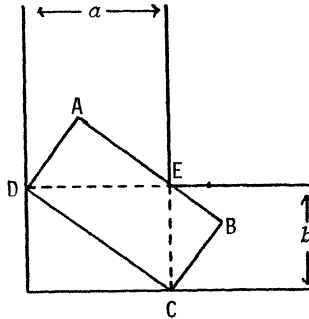

Figure 2

rotated around the corner if and only if the following two conditions are satisfied:

(a) it can be maneuvered into the position shown in Figure 1, with vertices C and D on adjoining outside walls and side AB touching inside corner E;

(b) when it is in the position described in (a), the instantaneous center of rotation is at E.

Since the paths of C and D are known (the outside walls), the instantaneous center of rotation is the intersection of the normals to the walls at C and D. It follows that the largest rectangular plate that can be rotated around the corner is the one shown in Figure 2, with dimensions $CD = \sqrt{a^2 + b^2}$ and $BC = ab/\sqrt{a^2 + b^2}$, and area ab .

Thus a rectangular plate can negotiate the corner only if it has area $\leq ab$, and those of dimensions

$$a \times b \quad \text{and} \quad \sqrt{a^2 + b^2} \times \frac{ab}{\sqrt{a^2 + b^2}}$$

are the only ones in which this maximum area is attained.

Also solved by W.J. BLUNDON, Memorial University of Newfoundland; M.S. KLAMKIN, University of Alberta; VIKTORS LINIS, University of Ottawa; DAN SOKOLOWSKY, Antioch College, Yellow Springs, Ohio; and the proposer. Comments were received from BASIL C. RENNIE, James Cook University of North Queensland, Australia; and KENNETH M. WILKE, Topeka, Kansas.

Editor's comment.

For lack of space, an interesting comment on this problem by M.S. Klamkin, which was intended to follow solution I, will appear only in the next issue.

*

*

*

SIC TRANSIT...

In Ivan Turgenev's *The Torrents of Spring*, there is a poodle named Tartaglia.